

MINUTES

**Massachusetts Health Information Technology Council
Meeting
August 19, 2009
9:00 – 10:30 am**

**Matta Conference Room
One Ashburton Place
Boston, Massachusetts**

MINUTES

MASSACHUSETTS HEALTH INFORMATION TECHNOLOGY COUNCIL

August 19, 2009

Attendees:

Council Members JudyAnn Bigby, MD - *(Chair) Secretary of Health and Human Services*
Deborah Adair - *Director of Health Information Services / Privacy Officer*
at Massachusetts General Hospital
Karen Bell, MD - *Senior Vice President of HIT Service at Masspro*
David S. Szabo - *Partner with Nutter, McClennen & Fish, LLP*
Meg Aranow - *VP & Chief Information Officer, Boston Medical Center*

Other Joel Weissman (EOHHS)
Kimberly Haddad (Committee on Health Care Financing - Senate)
Bert Ng (Committee on Health Care Financing - House)
Adam Delmolino (Mass Hospital Association)
James Fuccione (Home Care Alliance)
Greg Mancusi-Ungaro (Health Alliance)
Dee Dee Edmondson (Rasky Baerlein)
Barbara Klein (Concordant)

MTC Staff Glen Comiso
Bethany Gilboard
Rick Shoup
David O'Brien
Barbara-Jo Thompson

Deloitte Staff Doug Beaudoin
Michael Marino
Lisa Sherwin
Randy Gordon, MD
Kevin Carr, MD
Hussein Jaffer

The twelfth meeting of the Massachusetts Health Information Technology Council was held on August 19, 2009, in the Matta Conference Room at One Ashburton Place in Boston, Massachusetts.

Secretary Bigby called the Meeting to order at 9:00 a.m.

Secretary Bigby introduced to the Council members Meg Aranow. Meg is going to be newest member of the HIT Council. The Secretary gave a brief background on Ms. Aranow, explaining that she is the CIO at Boston Medical Center and has been very involved in Community Health.

She then gave Ms. Aranow a chance to address the Council. Ms. Aranow stated that she has been actively involved in HIT for 25+ years, 10 years at Brigham and Women's and now at Boston Medical Center. She further stated that she has a lot of experience in EMR and CPOE implementation. And while being a neophyte to public policy, she is looking forward to learning.

Council Members then went around the table and introduced themselves to Ms. Aranow.

AGENDA ITEMS

I. Review and Approve Minutes of August 6

After motions made and seconded, it was unanimously agreed to accept the draft minutes as the official minutes of the August 6th meeting.

II. MeHI Director Recommendation

Karen Bell gave an update on the search and recommendations for the position of the MeHI Director.

Dr. Bell explained the process involved. Over 100 applicants responded to the job opening and were narrowed down to 35 candidates. Their resumes, qualifications and references were compared against the criteria by a review committee.

The Review Committee:

- Dr. Karen Bell, HIT Council Member
- David Martin, Legislative and Policy Affairs Director, EOHHS
- Mitchell Adams, Executive Director, MTC
- Judy Silvia, Director of Regulatory and Government Affairs, MTC
- Edy Anako, HR Director, MTC

Criteria Included:

- Leadership
- Understanding of Stakeholders
- Understanding of Delivery System
- Understanding of Payers & IT
- Understanding of Public Stakeholders
- Others

After the initial review, it came down to 5-6 candidates that made the first cut. The committee insured those candidates were well vetted and then they met and reviewed those applications in

detail. The next step had Mitchell Adams, in his role as the Executive Director of MTC; follow up with each of the candidates relative to interest, expectations, compensation, etc. It then came down to three viable candidates, who interviewed in person with the committee. Initially the thought was that this process would be very competitive but then it was realized that it came down to Leadership skills, communication and presentation skills, and the breadth and depth needed for the position.

All 3 candidates were presented to Secretary Bigby. It was unanimous that there was one candidate that was hands down the one to hire. Therefore the committee makes a recommendation to the Council, that Dr. Richard Shoup become the Director of MeHI.

Secretary Bigby then made a note of clarification. Mitchell Adams will receive the recommendation from the council. But first it is important for the council to have the opportunity to ask any questions they may have to the candidate in an executive session. Then once it is determined they are all in agreement a final decision will be forwarded to Mitchell Adams.

Secretary Bigby then instructed all observers and attendees, that the Council will now meet in Executive Session (staff and observers were asked to leave the room) so that the Council members may have an opportunity to ask questions of Dr. Shoup.

Break at 9:12 a.m. for Executive Session

The HIT Council meeting resumed at 9:34 a.m.

After motions were made and seconded it was unanimously approved to recommend Dr. Richard Shoup to Mitchell Adams as the Candidate for the position of MeHI Director.

Secretary Bigby turned the floor over to Lisa Sherwin of Deloitte. Ms. Sherwin introduced Doug Beaudoin, managing partner of Deloitte who was unable to attend the last Council meeting. She then introduced Kevin Carr to give today's presentation to the Council.

III. Discussion of Plan with Deloitte: Status and Working Discussion

Dr. Kevin Carr began with an overview of the project timeline and asked Council members if they had any questions.

Mr. Szabo stated that Ms. Fenichel was not able to attend today's meeting, therefore on her behalf he wished to follow up on an email she had circulated. The concern being that there is currently not a specific planning track for consumer issues. Since Ms. Fenichel had issued a strong opinion on this matter he thought it best to bring that to the discussion.

Dr. Carr responded that in every issue that is the number one question asked, "How do we engage the consumer." So it is the forefront in everyone's mind. You will notice the consumer piece throughout today's presentation.

He went on to explain that since the project began they have had 3 site visits, (North Adams, Brockton, and Newburyport.)

They have also had conversations with the council members that are serving on the various streams and it was quickly realized that they should combine the work streams of EHR/HIE.

Another thing realized was getting all stakeholders in one room to focus on lessons learned moving forward was very important. So this past Monday, August 17th, they did just that at the Deloitte offices. A list of participants and the presentation from that focus group are in today's meeting packet (and incorporated into the minutes)

Dr. Bell stated that she has noticed that everyone is doing great job under a lot of pressure.

Dr. Carr directed the Council's attention to two slides in the presentation; one represented the meetings they have held, and the other included meetings that are currently scheduled. He then asked Council members that if they noticed anything missing from either individual meeting lists or other focus groups, to let them know.

Next he walked through the guiding principles (listed here)

The Massachusetts eHealth Institute will develop a statewide health information technology plan that will:

- ◆ Support patient-centric care coordination within and among communities across the state and surrounding states
- ◆ Minimize disruption of patient care
- ◆ Empower all Commonwealth residents
- ◆ Support the Commonwealth's public health surveillance and improvement initiatives
- ◆ Improve healthcare system clinical outcomes
- ◆ Improve healthcare system efficiency, resulting in better value for Commonwealth residents

He then paused for feedback and comments

Ms Adair asked whether this is principles or outcomes.

Secretary Bigby added a few things she would like to see reflected in principles:

- ◆ Patient centric care, integrated in a system. Higher systems level statement. And the patient will experience it as well.
- ◆ No mention of Quality mentioned here. Must state right up front quality of care will improve.
- ◆ This will explicitly support improved care in vulnerable populations.

Dr. Bell added that the concept of stewardship must be addressed, that those dollars are spent in the best way possible. Dr. Carr concurred that topic came up in the focus group as well.

Mr. Szabo added that something must be stated about privacy and security on the front end

On the Council's recommendations it was agreed that the guiding principles would be edited.

Dr. Carr then proceeded to a discussion on, "What is required to make guiding principles a reality?" (Listed here)

- ◆ Actionable data at Point of Care
- ◆ Analytics to evaluate healthcare system value
- ◆ Revise patient experience and expectations
- ◆ Consistent HIT and business practices across communities
- ◆ Statewide governance process
- ◆ State to state interoperability for those states with whom we would exchange information
- ◆ Provide secure and reliable access to patient information (meeting HIPAA and other federal/ state requirements)
- ◆ Provide platform for implementation of leading evidence-based medicine practices aimed at improving patient safety
- ◆ Create and ensure sustainable business model for both HIE and EHR implementations
- ◆ Create and sustain workforce to support the initiative
- ◆ Support the economic engine of the Commonwealth

Dr. Carr pointed out that the Governance process is important on the front end and they plan to update this to include consumer involvement as well.

Next was a discussion of the "Straw Model Framework." (Graphic attached) From internal and external discussion Dr. Carr stated we all realized this is an evolving framework moving forward.

Funding would reside in an eHealth fund. MeHI (a division of MTC) would serve as the Regional Extension Center (REC). This is important since we want to be able to maximize the funding that the Commonwealth could qualify for and be able to better leverage other funding opportunities through a state match of funds. There would be a Program Management Office (PMO) within MeHI that would focus on EHR and HIE and the Implementation and Optimization Organizations (IOOs). Health Information Exchange (HIE) can occur at the local level, and we would also have a statewide HIE. We should insure that all participants involved get the most value for the dollar.

Dr. Bell pointed out that this picture does not reflect Hierarchy or Fund flow. Also we spoke of a certifying body, a structural piece, which must be included. Ms Adair added there were good discussions in the focus groups around this graphic.

Ms. Aranow asked if the two lower levels are examples, or does it represent what will be? Dr. Carr responded that it will change over time.

Straw Model Framework:

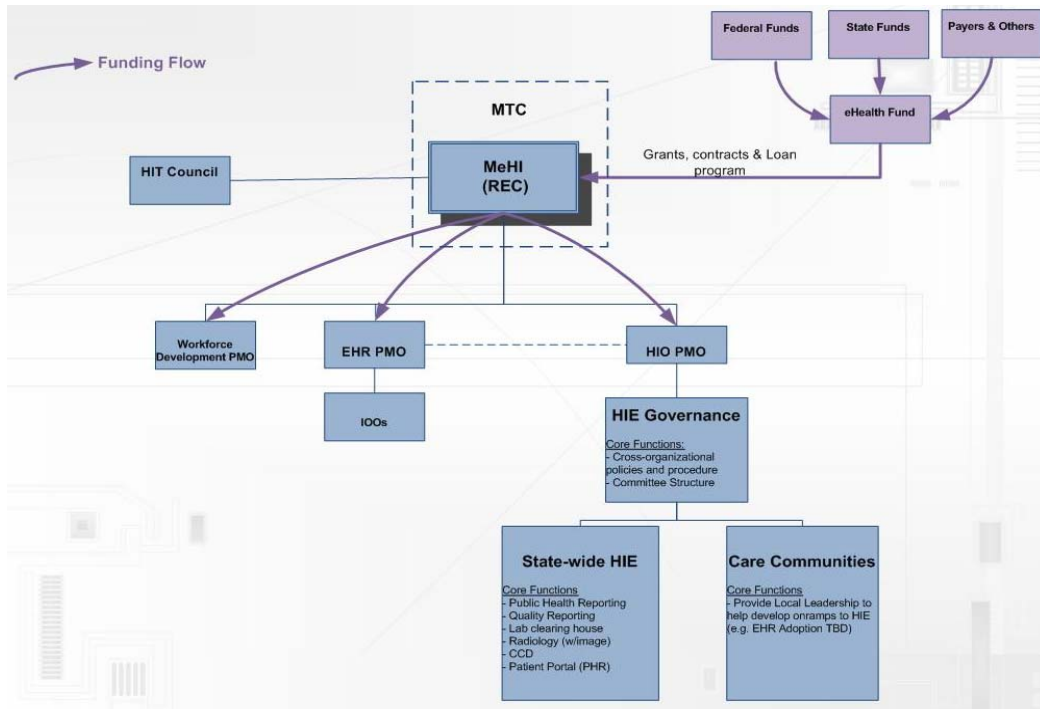

High-Level Organizational Roles in Straw Model

MeHI

- ◆ Serve as the Regional Extension Center (REC)
- ◆ Make recommendations to HIT Council and MTC Board concerning allocation of funds in the eHealth fund
- ◆ Program Management Office

Workforce Development PMO

- ◆ Support community of practice
- ◆ Serve as Advisors and Liaisons to educational institutions and employers

EHR PMO

- ◆ Project Management oversight of IOOs

HIO PMO

- ◆ Provide support for governance of HIE implementation and operational management

Secretary Bigby asked for a little clarity on the bottom two boxes, what does this represent?

Answer: That is what is in discussion; what needs to be governed? For example, how information is used has come up repeatedly in discussions so this must be included in the governance structure. There will be some procedures that are both statewide and local, but all this needs to be discussed.

Secretary Bigby stated that HIE governance is not a bunch of committees siloed. Dr. Carr responded currently in discussion is the organization of governance. Would it be a separate organization, what structure needs to be in place, etc? They welcome all input.

Ms. Adair reminded the Council that there was a lot of input at focus groups to not separate out HIE and EHR. Dr. Bell added that everyone wishes to make sure the state gets overarching goals that are to be met and that are eventually linked.

Mr. Szabo pointed out that there are existing rules that affect everyone in the state (e.g., HIPPA). In reading Chapter 305, there are additional requirements or standards that apply to individuals who get assistance from eHealth funds. Think about what are the shape and limit of HIE Governance that have been given in Chapter 305. If someone builds and HIE in the basement and doesn't use funds, do we have any say in what they do?

Dr. Bell explained there is a difference between and HIE and a Care community. There is real governance around statewide HIE. How are we going to do it, what are the priorities? The governance and what care communities can link in. We can't discuss governance at a local level unless they link into HIE.

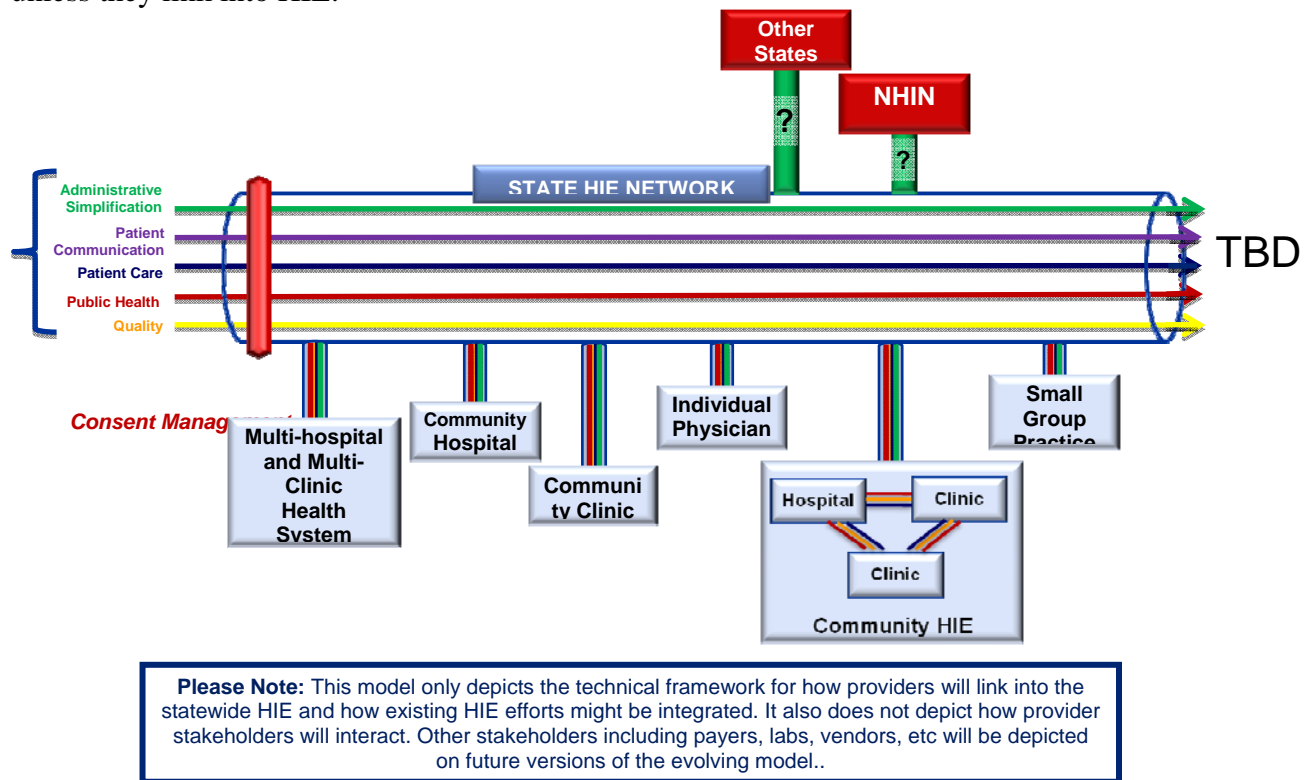

Core function is managing consent and to insure data gets to the right people not to the wrong people.

Dr. Shoup added that they have been in conversations with adjoining states on where we can coordinate and where the opportunity for collaboration can exist.

Secretary Bigby stated that in this there is no portal for a patient to link into a Personal Health Record. Dr. Carr said it is included, but that needs a lot of discussion. What do we want the

patient experience to be, what are the activities we want to provide at a local level, and what are at the state level?

If all providers can exchange information on a patient, then people will have records in multiple places. There ought to be a way for a record to show all the things that happened to that patient at those multiple locations.

Dr. Bell reminded everyone that this represents providers. We must discuss what happens to the patient over time. Dr. Carr thanked the Secretary and Dr. Bell for those points and added we must continue to have discussions on where the records reside.

Ms Aranow suggested that we could encourage that providers provide access to the patient.

Lastly, Secretary Bigby suggested that everyone look through all the information that was distributed, and provide feedback on the items they understand and ask questions on things they do not. She also stated that we may need to determine if our meetings need to be longer during this planning process.

Meeting adjourned 10:32 am.